



HOME
COLLECTION
SALONE 2019

OASIS



OASIS STORY

There is only one area of Italy where the air can blow in from foreign lands, that place is Friuli. And along with that wind comes history, style and certain ways of thinking.

It is here that the story of Oasis began, the result of a refined and eclectic merging of different cultures, civilisations, languages and cuisines often referred to around the world as "Italian style".

1908

Floriano Quaia opens his first carpentry workshop: a small studio where furniture is made with the aim of lasting a lifetime.

1945

Bernardo Quaia, son of Floriano, sets down the foundations of a company where the first pieces of decorative furniture would later be developed.

1972

Francesco, Bernardo's son, builds a factory and creates - using his surname - an actual brand. Together with his brother Floriano, he sets up Arredamenti Quaia.

1980

Arredamenti Quaia participates in the Salone del Mobile, Milan for the very first time. The accompanying burst of innovation marks a turning point for the company which sets its sights on ever broader horizons.

1984

During the flurry of the Eighties, Francesco Quaia establishes the Oasis brand, branching out into the production of bathroom furniture which thereafter becomes part of the company offer.

The New Millennium

At the turn of the Millennium, an impetus of change, of fresh new ideas, sweeps through the company in the form of the next generation, Francesco's three children: Francesca, Federica and Lorenzo.

2001

The eldest, Francesca, is the first to work alongside her father in the business and, as assuming responsibility for the commercial direction of the company, is pivotal in steering it along the road to internationalisation.

2005

It sees the setting up of the first international base for the company, in the city of Moscow. Warm and harmonious Italian spirit meets the essence of regal Russia and the two succeed in winning one another over.

2006

Second daughter Federica, having specialised in the worldwide branding of luxury goods, takes over all aspects of image and communication within the company, thus assuming marketing and artistic control.

2008

Third-born Lorenzo completes the transition to the fourth generation. Specialising in project research and development as well as highly technical products, he becomes head of the technical production division.

2012

The Home line is completely revised and relaunched with the aim of offering, under the Oasis label, a complete and coordinated luxury interiors package inspired by the language of cosmopolitan and contemporary style.

2013

2013 sees monobrand flagship showrooms opening in both London and Hong Kong.

2016

Oasis selects the historical and very famous Libreria Bocca in Galleria Vittorio Emanuele II in Milan, as the exclusive location to display items from its collections, resulting in a coming together of two areas of Italian supremacy: culture and style.

The principal aim of the company was to locate the best environment in which to showcase to the general public their perhaps less conventional furniture items.

2017

Oasis celebrates the opening of a new showroom, focused on luxury bathrooms and located in the heart of Milan.

2018

During Salone del Mobile 2018, Oasis introduces the first issue of "Oasis World", a publication that explores the company's iconic look and philosophy in the world markets.

At the same time, the Oasis brand is expanding its presence in the Chinese market with the opening of another luxurious showroom in the vibrant city of Shanghai.

Nowadays

The company is a century-old family business characterised by courage, tradition and a strong identity. It has market presence in more than 25 countries, the main ones being: Russia, China, Ukraine, the United Kingdom, Germany, France, Switzerland, Belgium, India and the United States.

The Oasis production portfolio includes a wide range of furniture collections for the Home, the Bathroom and the Contract industry for the construction of projects for both residential and professional purposes.



OASIS HOME

Oasis Home Style

2019

In order to achieve the “total look” for maximum impact, Oasis has for some years been perfecting the Home collection which comprises items to furnish all areas of the house.

Inspired by the International Style of the 1920s and ‘30s, as well as the Masters of Industrial Design of the 1940s and ‘50s, Home Collection provides the complete design package thanks to the customisation and versatility of its products. Marble in diverse colours and varieties sits alongside various wood types to create furniture with a bold character.

Statement pieces featuring specific materials and unique designs or exquisite “showcase” items incorporating precious metal finishes add an allure and fascination to furniture collections befitting the most luxurious of residences.

All this thanks to a wealth of materials, fabrics and finishes which can completely transform the look and atmosphere of an environment to appeal to all manner of tastes and desires.

*Captivating
Coral*
Living Room

DAHLIA sofa, SULLIVAN side table,
SULLIVAN coffee table, MUFFIN DELUXE
pouf, ZOE small armchair, STRADIVARI
suspended lamp with triple unit,
STRADIVARI wall lamp with single unit.











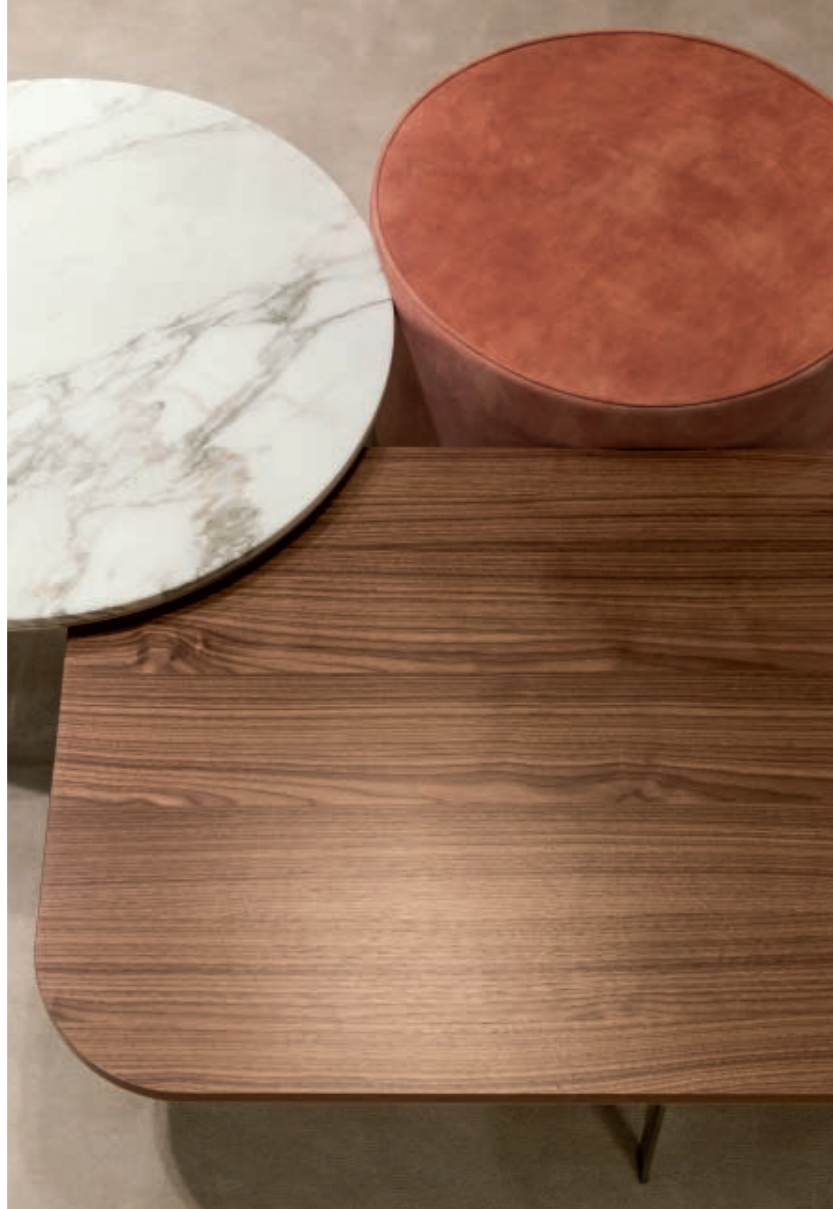





*Marsala
Inspiration
Dining Room*

TURNER table - round version, MUSA 1 chair, MOON suspended lamp with five units, ACADEMY bookcase, ACADEMY buffet, DUPRE' mirror, MOON wall lamp, ACADEMY bar cabinet - version 1, MOON table lamp.







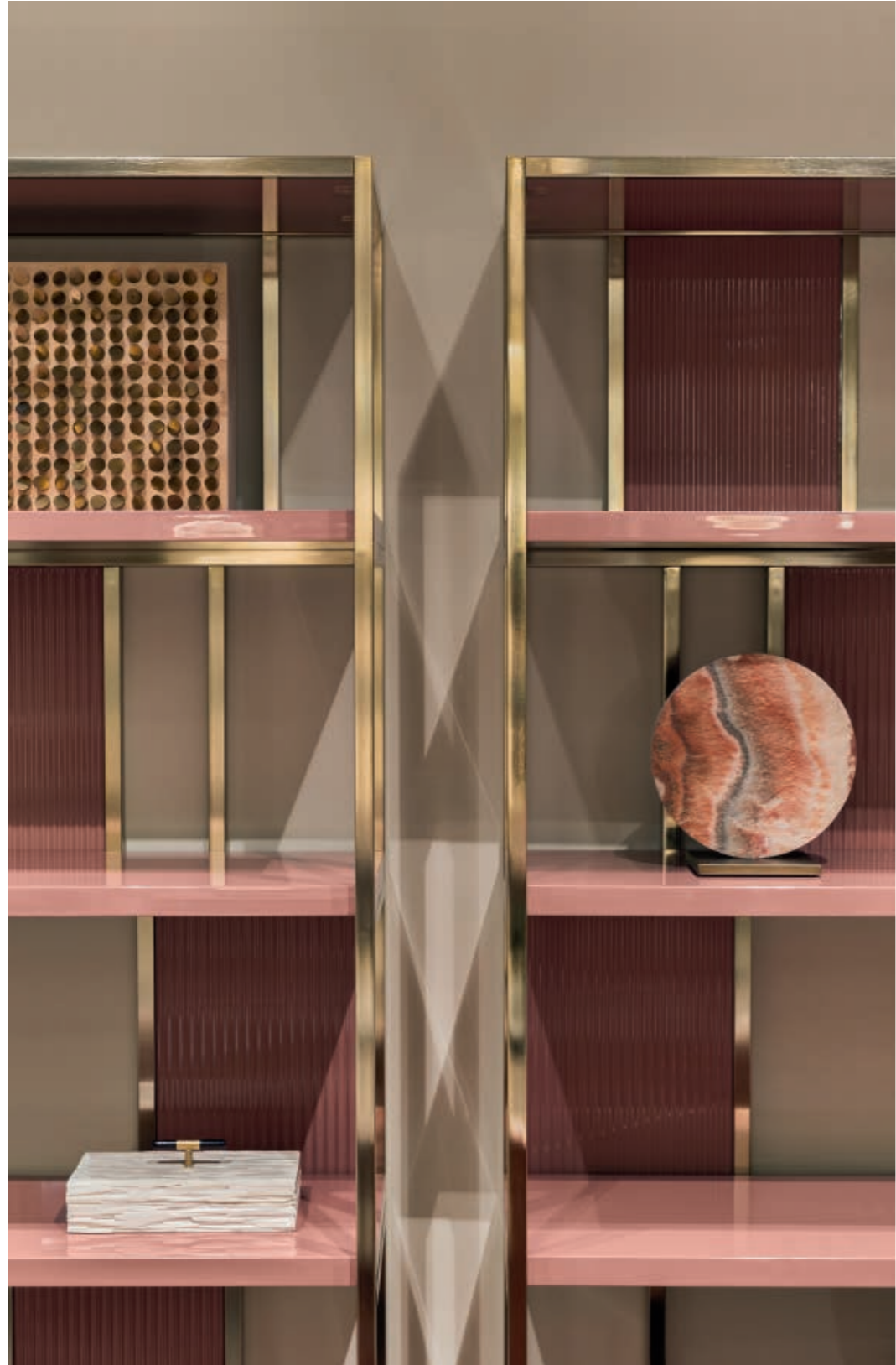









*Sensory
Cascade*
Entrance

MEDEA console, EVELYNE armchair,
MEDEA side table, PSICHÈ mirror, FEBE
armchair.











*Echoes Of
Spring
Hallway*

SATEN armchair, ANDRÈ side table,
STRADIVARI table lamp, DAMA writing
desk, JULES chair, VALENTINO mirror.









Subtle Sage

Dining Room

TURNER table - oval version, MUSA 1 chair, MUSA 2 small armchair, EDGE horizontal suspended lamp with triple unit, ACADEMY bookcase, ACADEMY writing desk, VALENTINO mirror, EDGE wall lamp - small version, ACADEMY bar cabinet - version 2, ACADEMY console with and without tray, EDGE table lamp, SULLIVAN side table.















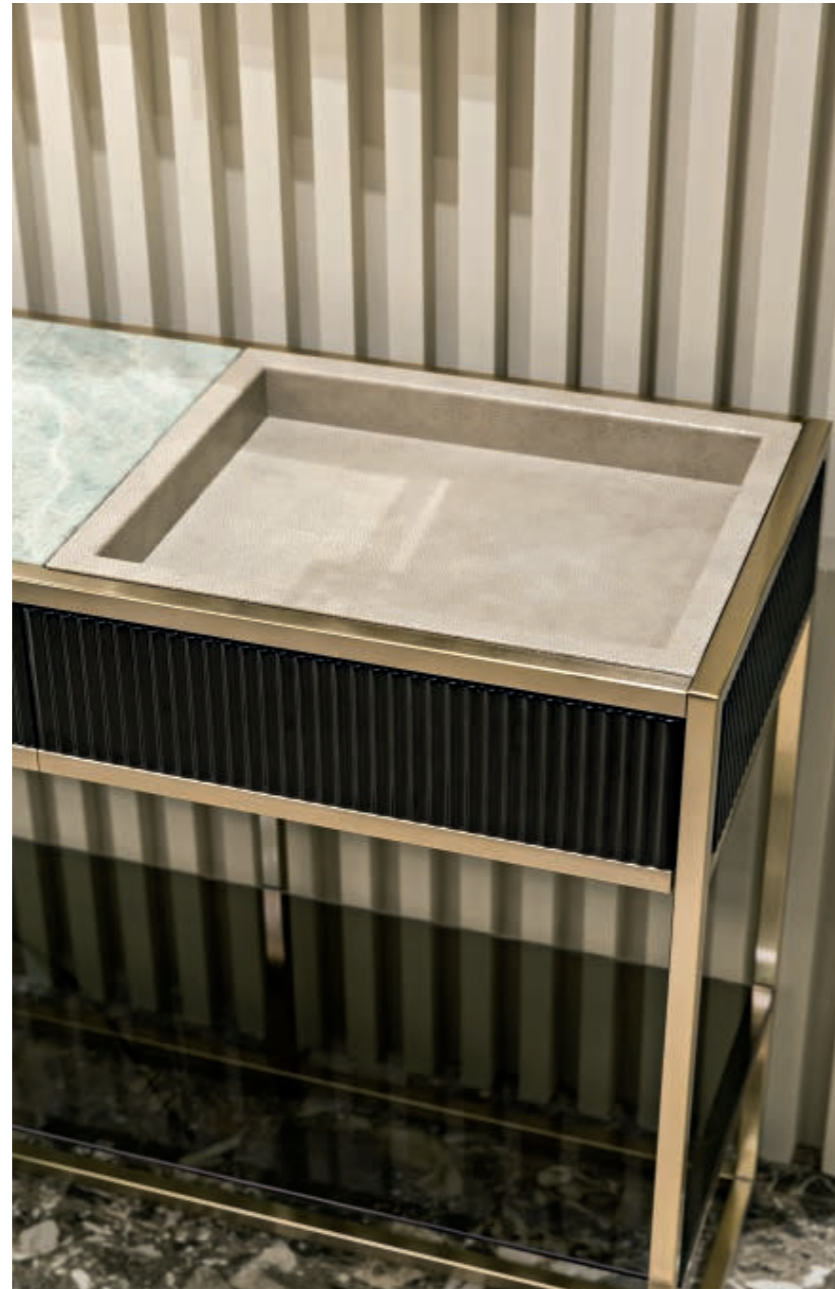





Mélange of Materials

Living Room

HERBERT sofa, ACADEMY coffee tables collection, ECLISSE 3 mirror, EDGE vertical suspended lamp with triple unit, HECTOR coffee table, EDGE wall lamp - big version, EVELYNE armchair, KATE armchair, EDGE floor lamp.





DÉCO















Metal & Marble

“Salle De Bain”

Bathroom

ACADEMY vanity unit (L190 x W54 x H210 cm) with “Ribbed decoration” in Cemento finish and gold metal finish structure. Bianco Statuario marble top and white ceramic undercounter washbasin.

ACADEMY mirror (L190 x W2 x H100 cm), MURANO 4 wall lamp, CHARLOTTE taps.

ACADEMY pouf (L39 x W39 x H53 cm).

ACADEMY dressing table, ELEONOR pouf.

ACADEMY vanity unit (L110 x W54 x H210 cm) with “Ribbed decoration” in Lino finish and chrome metal finish structure. Calacatta Oro marble top and white ceramic undercounter washbasin.

ACADEMY mirror (L110 x W2 x H100 cm), MURANO 1 wall lamp, CHARLOTTE taps.

ACADEMY tall unit with one door (L35 x W35 x H156 cm) and ACADEMY free-standing towel holder (L50 x W39 x H84 cm).

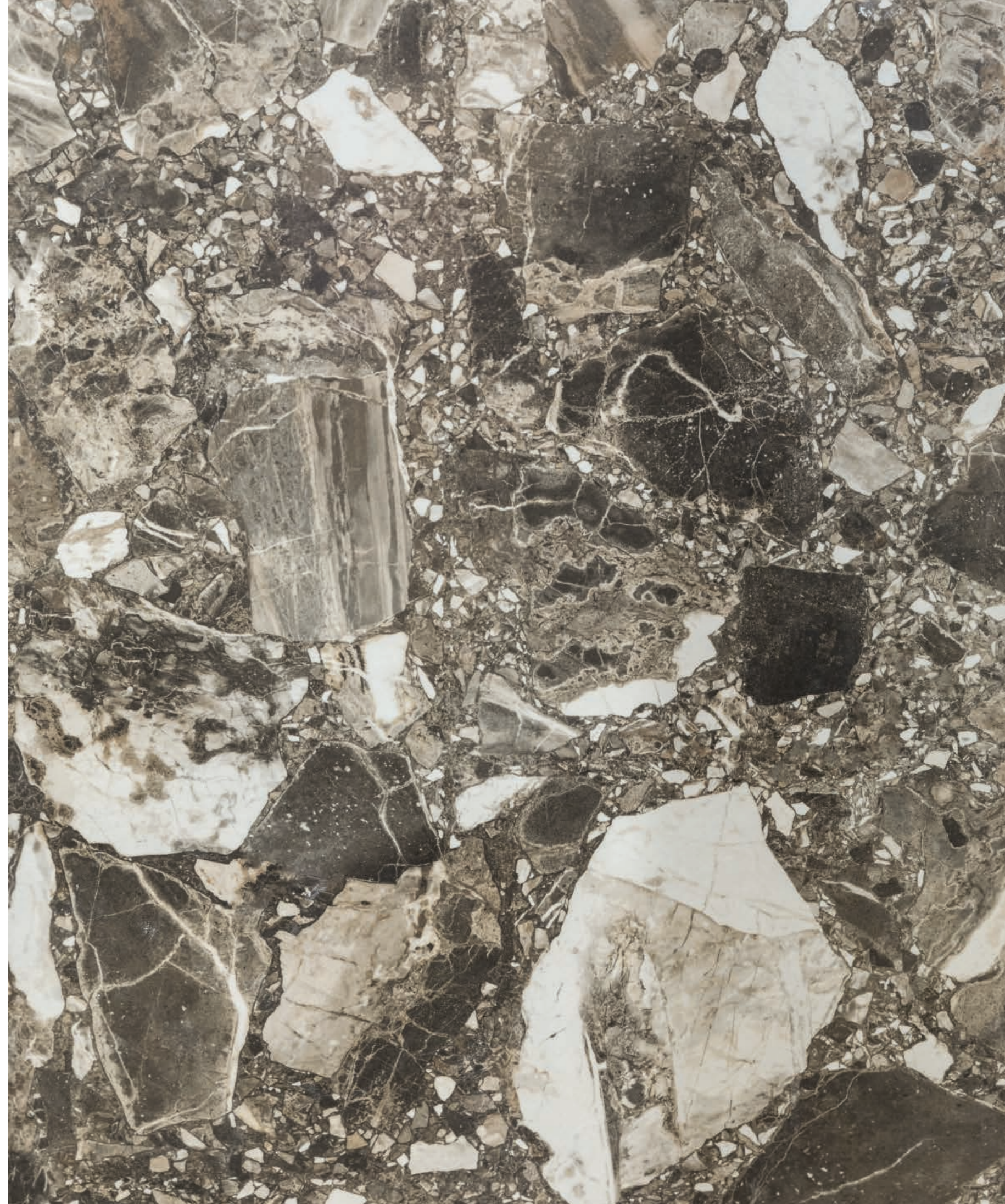













TECHNICAL DATA

LIGHTING



Edge

Vertical
Pendant
Lamp
3 units

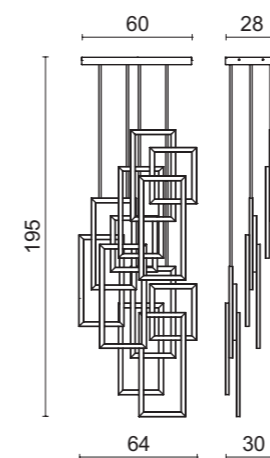

Edge

Horizontal Pendant Lamp - 3 units

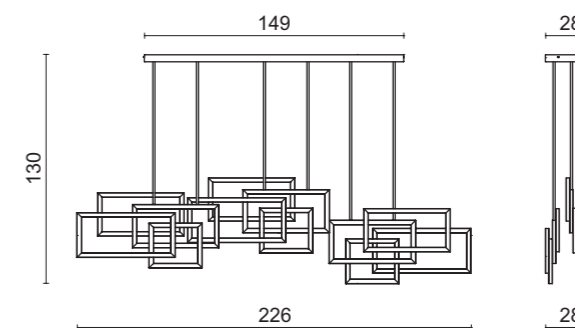

Edge

Table Lamp

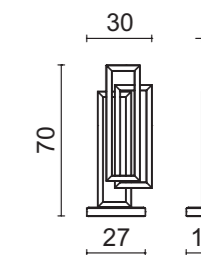

Edge

Wall Lamp
Big Version

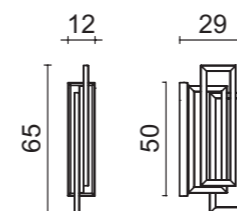

Edge

Wall Lamp
Small Version

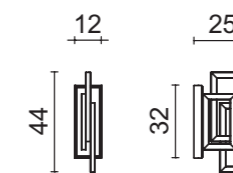

Edge

Floor Lamp

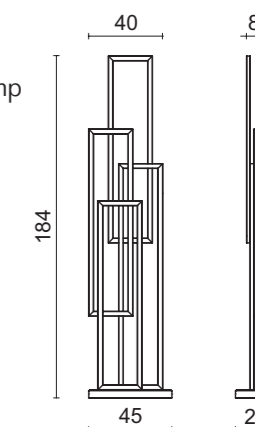

Moon

Pendant
Lamp
5 units

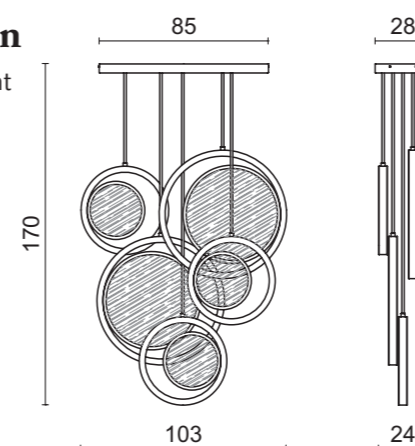

Moon

Table Lamp

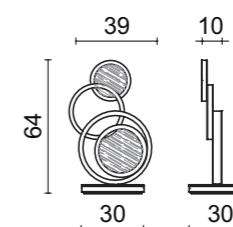

Moon

Wall Lamp

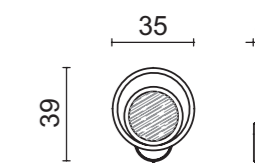

Stradivari

Suspended
Lamp

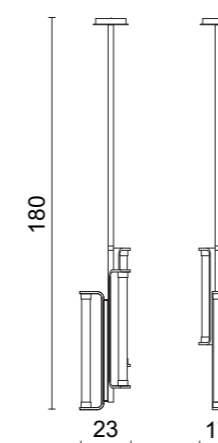

Stradivari

Wall Lamp
Single Unit

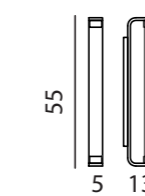

Stradivari

Table Lamp

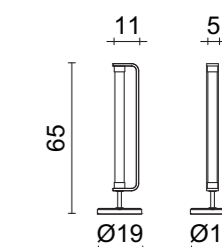



Dahlia Sofa

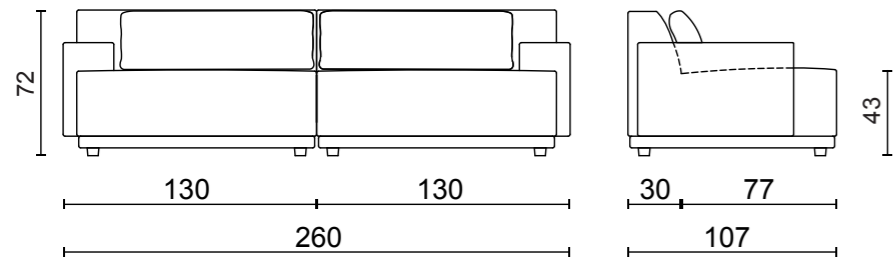

Evelyne Armchair

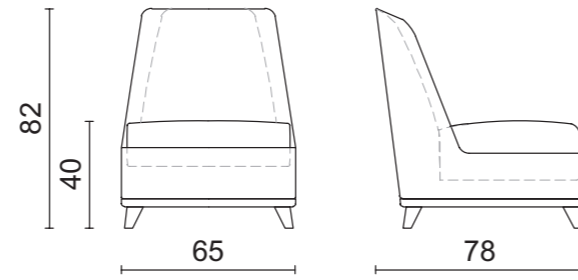

Eleonor Pouf (NEWS 2019)

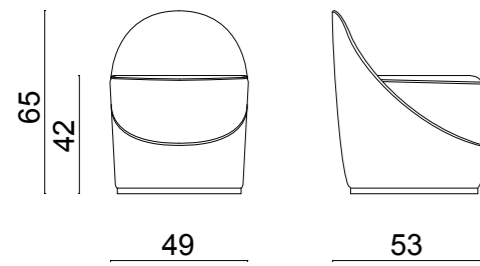

Febe Armchair

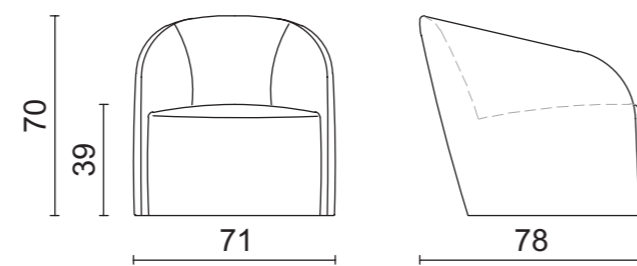

Herbert Sofa (NEWS 2019)

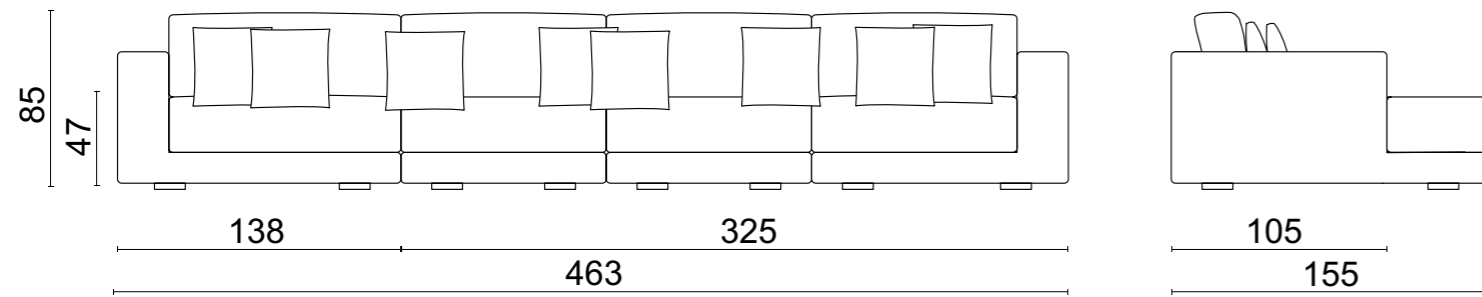

Jules Chair

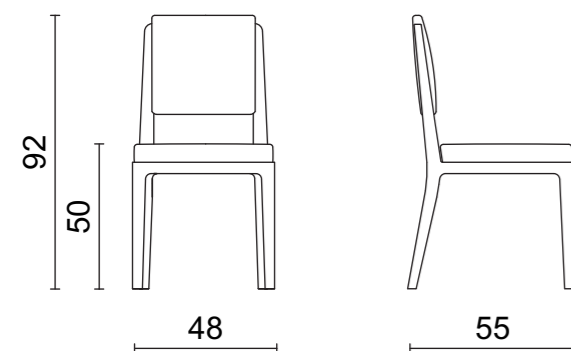

Kate Armchair

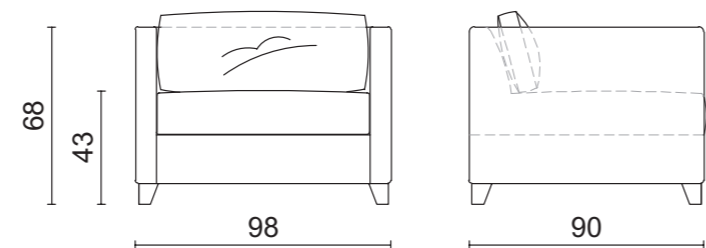

Muffin Deluxe

Pouf

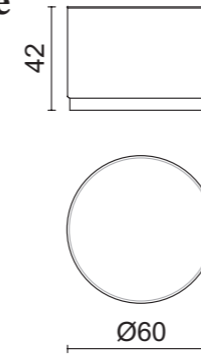

Musa 1 Chair

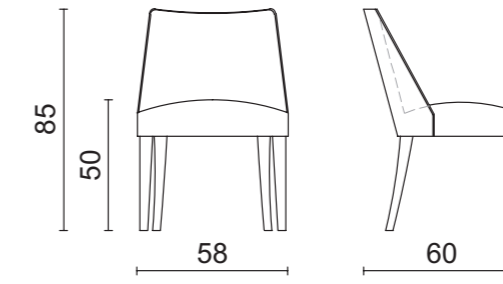

Musa 2 Small Armchair

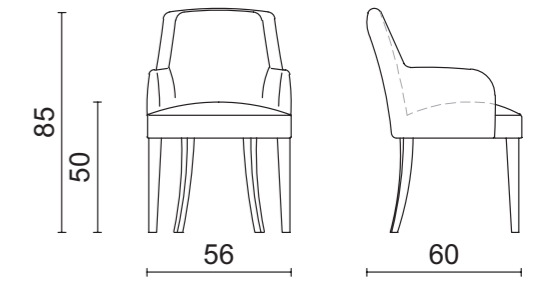

Saten Armchair

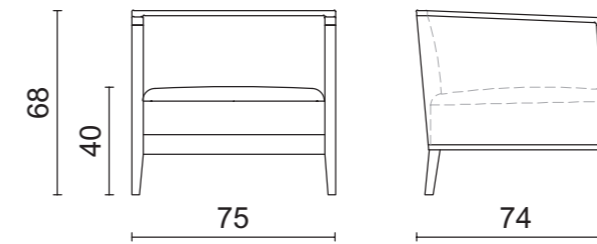

Zoe Small Armchair

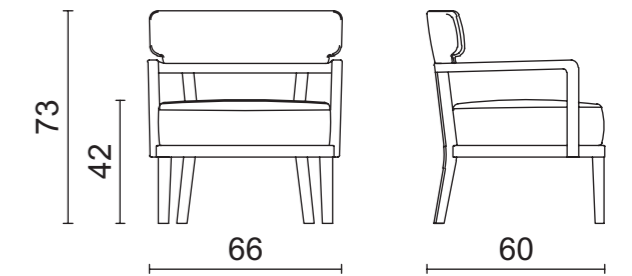

Duprè

Mirror

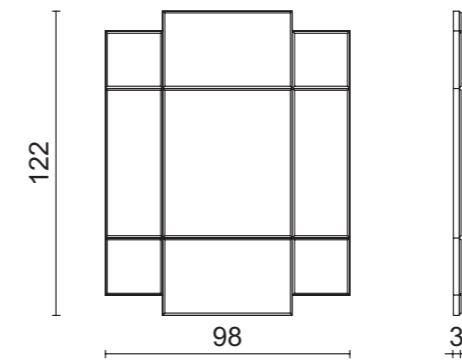

Eclisse Mirror

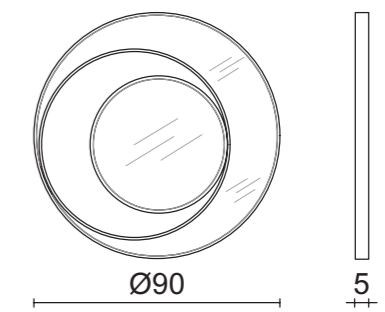

Psiché

Mirror

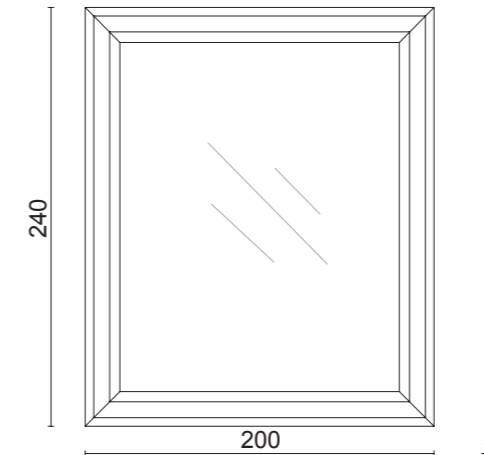

Valentino Mirror

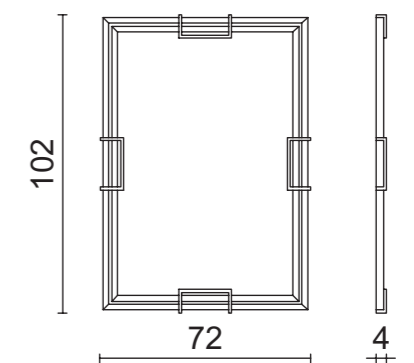



Turner

Table
Oval Version
(NEWS 2019)

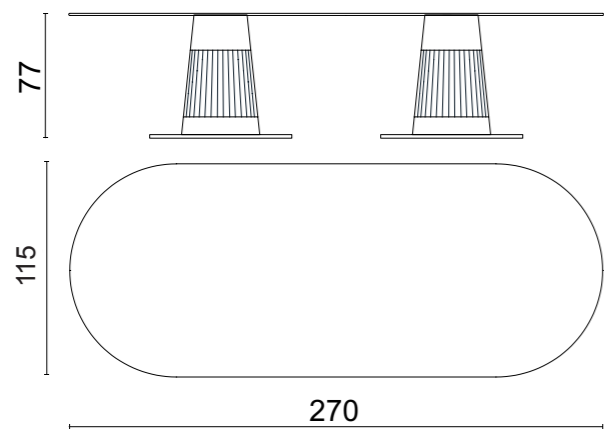

Turner

Table
Round Version
(NEWS 2019)

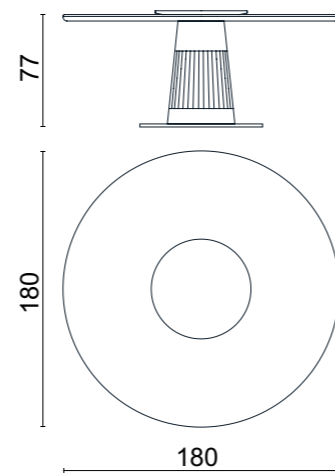

Academy

Coffee Tables Collection
(NEWS 2019)

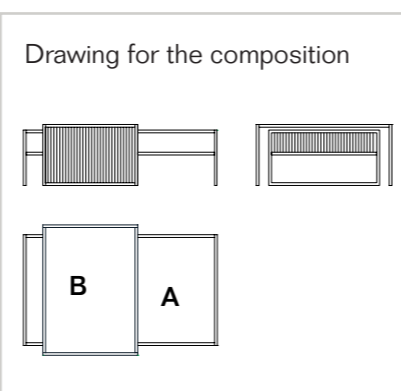
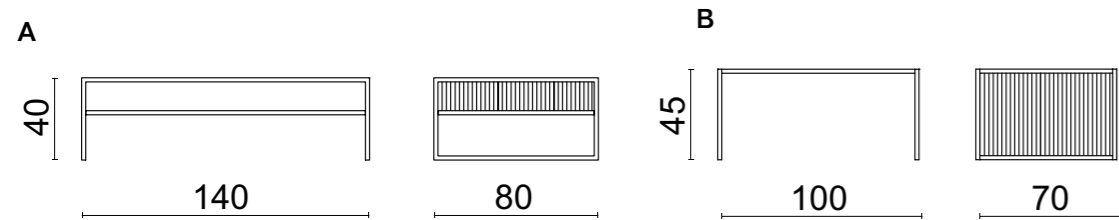

Andrè

Side Table

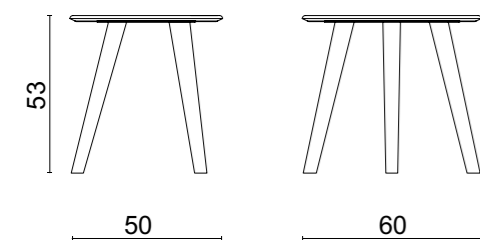

Hector

Coffee Table

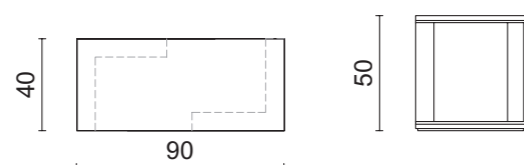

Medea

Coffee Table

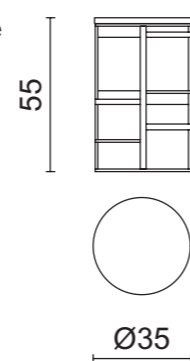

Sullivan Side Tables Collection

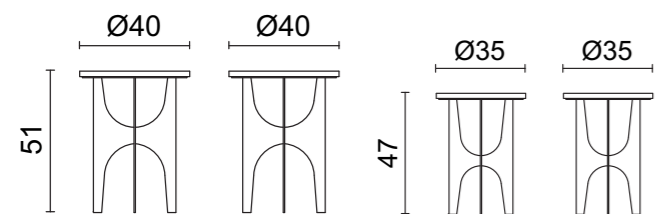

Sullivan Coffee Tables Collection (NEWS 2019)

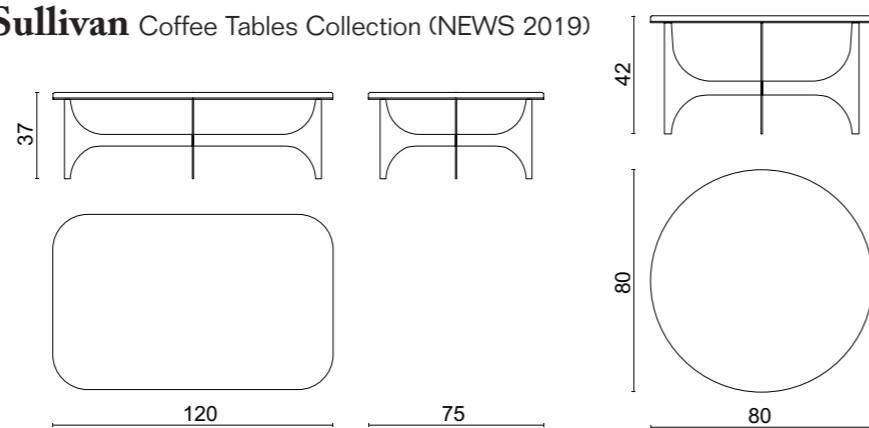

Academy Buffet (NEWS 2019)

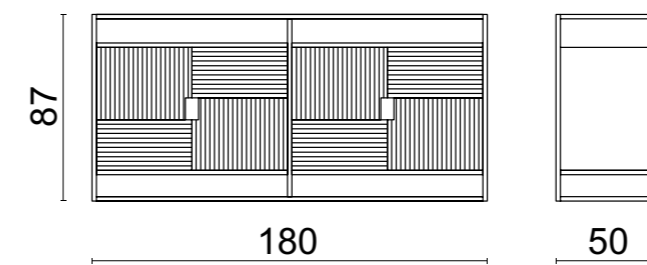

Academy Bar Cabinets Collection (NEWS 2019)

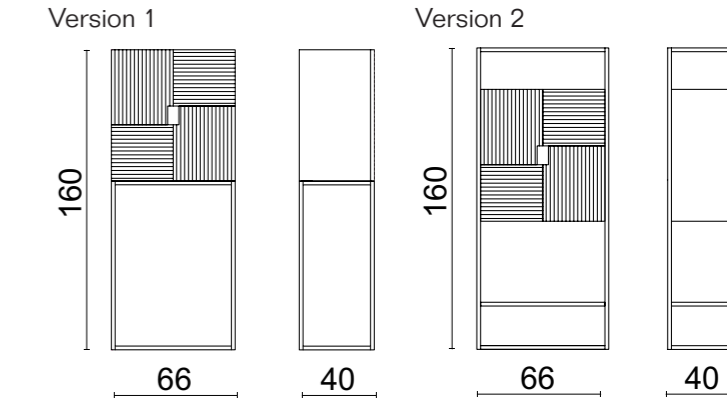

Academy

Bookcase
(NEWS 2019)

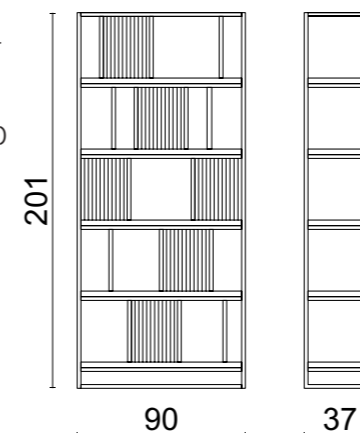

Academy

Console with Tray
(NEWS 2019)

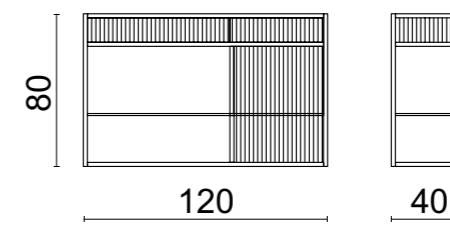

Academy

Console without Tray
(NEWS 2019)

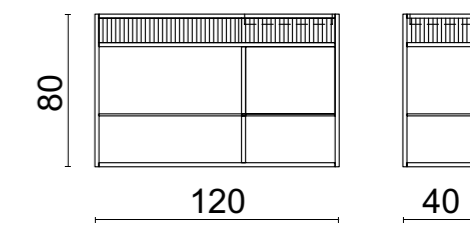

Academy Dressing Table (NEWS 2019)

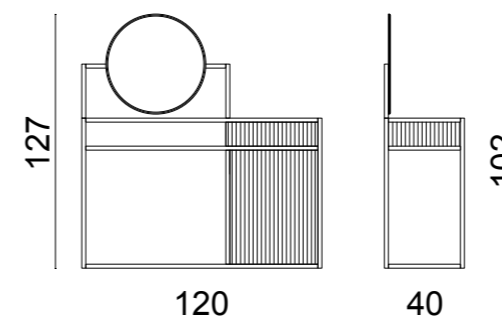

Academy Writing Desk (NEWS 2019)

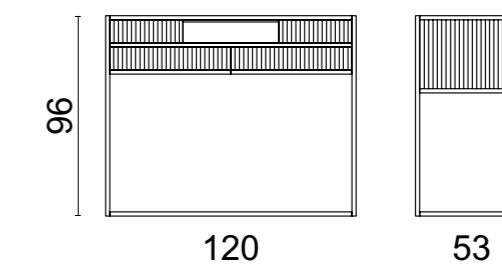

Dama

Console

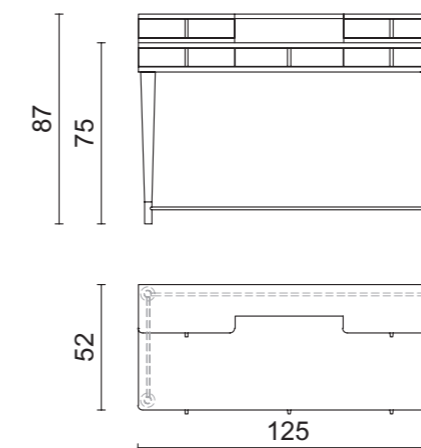

Medea

Console

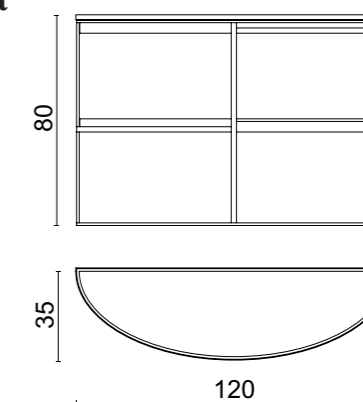



MADE IN ITALY

100% designed and made in Italy.

All Oasis products are protected by registered trademarks.

Oasis reserves the right to make all necessary modifications (in matters of colour, size and technical details) to its products in order to enhance their use and esthetic value.

Furthermore, it may suspend their production at any moment without notice. Such instances may not be subject to any claim on the part of the client.

Oasisgroup declines all responsibility for any possible uncertainties arising from misprints in this catalogue.

Ed.19 - Rev.01





www.oasisgroup.it